

ITEM NO.	QTY	MATERIAL DESCRIPTION	LENGTH	NOTES
1	4	HSS 2 x 2 x .188"	10.125 in	BASE TUBING
2	4	HSS 2 x 2 x .188"	39.500 in	BASE TUBING
3	6	HSS 2 x 2 x .188"	33.500 in	BASE TUBING
4	4	HSS 2 x 2 x .188"	6.125 in	BASE TUBING
5	1	HRS 12 GA x 37 1/2 x 43 1/2"		FLOOR SHEET
6	4	HRS 1/4 x 4 1/2 x 6 1/4"		SEE SHEET 6, CASTER PLATE
7	2	CASTER # CF 820 PTR-S		PURCHASED ASSEMBLY, SWIVEL CASTER
8	2	CASTER # CF 820 PTR-S-SB		PURCHASED ASSEMBLY, SWIVEL CASTER
9	16	3/8"-16 HEX LOCK NUT, NYLON INSERT, ZINC PLATED STEEL		PURCHASED PART
10	16	3/8"-16 x 1 1/2 HEX HEAD BOLT		PURCHASED PART
11	8	HRS 1/4 x 3 x 6"		CORNER PLATE
12	4	HRS 1/4 x 1 25/32 x 2 7/8"		SEE SHEET 6, CORNER WEDGE
13	32	3/8 WASHER, TYPE A, W, ZINC PLATED STEEL		PURCHASED PART
14	3	HSS 2 x 2 x .188"	11.833 in	BASE TUBING
15	1	ROUND HSS 1.05" x .125"	40.500 in	HANDLE
16	2	HSS 1 x 1 x .125"	24.000 in	HANDLE UPRIGHT

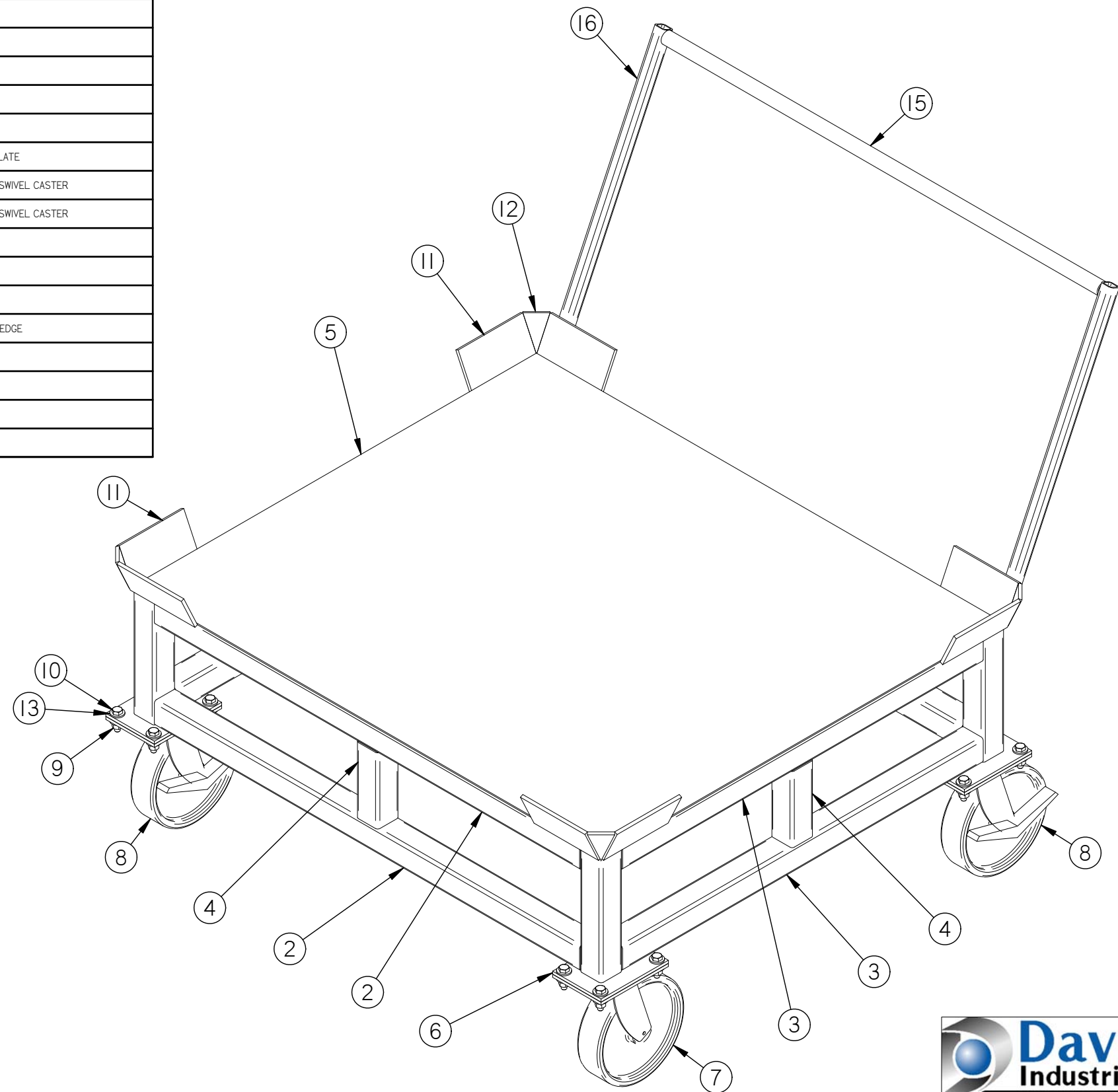

101 Amber Street, Unit 9
 Markham, ON L3R 3B2
 Phone: (905) 947-8100, Fax: (905) 947-0754

NO.	DESCRIPTION	BY	DATE	TITLE	UNITS
1	DESIGN CHANGE	CA	08-02-19	RIGID GALVANIZED CARTS	in
0	INITIAL ISSUE	CA	07-09-19		
REVISION HISTORY				PROJECT	
SHEET 1 OF 5				DRAWN C. ANNETT	
CHECKED D. KEEHL				DRAWING NUMBER RCGC-01	
UNLESS OTHERWISE SPECIFIED ANGLES ± 0.5° LINEAR ± 1/16"				REV 1	

EXAMPLE WEBSITE DRAWING